

COLLEZIONE



COLLEZIONE Rog



Puoi decorare **Sanitari, Mobili, Rivestimenti...**
Come desideri!

lavabi
complementi
luci
specchi
accessori



O.M.L. srl
via fattori 57 42044 gualtieri (reggio emilia) italy
+39.0522 tel. 828798 ra telefax. 828355
e-mail: info@oml.it <http://www.oml.it>

OML



**ESPRIMI LA TUA FANTASIA
EXPRESS YOUR FANTASY**

IL FIORE:

È una particolarità dell'intera collezione. È stato creato per dare la possibilità di personalizzare, esprimendo la nostra fantasia, la stanza da bagno;

si possono decorare lavabi, complementi, specchi, rivestimenti.

In tema, a completamento sono stati realizzati anche accessori, piantane, appliques e plafoniere.

La collezione è composta inoltre di **lavabi, mensole, contenitori sotto lavabo, pensili e cassetti con apertura molto particolare.**

Particolare **attenzione** è da rivolgere al **cassetto** ed al **pensile**, due oggetti progettati per dare l'opportunità di usufruire di due funzioni in un solo elemento **appoggio e contenimento** per soddisfare qualsiasi esigenza.

La collezione permette di sviluppare piccoli arredamenti, colorati, giovani, ma anche arredamenti completi e raffinati come raffigurato a seguito.

FLOWER:

This pattern characterises the whole collection and allows you to customise your bathroom and express your fantasy at the same time.

For washbasins, complements, mirrors, and covers.

Moreover, thematic accessories, stands, wall lights and overhead lights are also available.

This collection also includes washbasins, shelves, under-washbasin containers, wall cupboards and drawers featuring peculiar openings.

In particular, the drawers and wall cupboard were designed in order to provide a single item serving a two-fold purpose and meeting all requirements of support and containing.

This collection allows to create small, coloured, young bathrooms as well as more complete and refined bathrooms, as shown below.

LA FLEUR:

C'est l'élément qui caractérise toute la collection. Il a été conçu dans le but de personnaliser notre salle de bain en donnant libre essor à l'imagination. On peut décorer des lavabos, des glaces, des revêtements et tout équipement.

Toujours dans le même esprit, des accessoires, des colonnes, des appliques et des plafonniers, complètent la série.

Cette collection comporte également des lavabos, étagères, des range-tout à placer sous le lavabo, des éléments muraux et des tiroirs ayant une ouverture spéciale. Le tiroir et l'élément mural sont particulièrement dignes d'attention, car ce sont deux objets conçus pour satisfaire tout besoin par un élément unique tout en assurant deux fonctions en même temps: l'appui et celle du conteneur.

Cette collection permet de réaliser un mobilier jeune et coloré, petit mais aussi complet et raffiné, ainsi qu'on peut le voir ci de suite.

DAS BLUMENORNAMENT:

... ist eine Besonderheit der gesamten Serie. Es wurde entworfen, um allen die Möglichkeit zu gewähren, dem Badezimmer eine ganz persönliche Note zu verleihen und der eigenen Fantasie freien Lauf zu lassen.

Mit diesen Motiven kann man Waschbecken, Spiegel und sämtliche Verkleidungen dekorieren.

Für alle diejenigen, die ein einheitliches Bild im Bad lieben, wurden passend dazu auch Badzubehör, Ständer, Wand- und Deckenleuchten entworfen.

Die Serie besteht weiterhin aus Waschbecken, Regalen, Unterschränke für Waschbecken, Wandschränke und Behälter mit origineller Öffnung.

Besondere Aufmerksamkeit verdienen der Behälter und der Wandschrank, zwei Gegenstände die entwickelt wurden, um allen Erfordernissen gerecht zu werden und somit also zwei Funktionen in einem Element zu vereinen: Ablage- und Stauraum.

Die Serie gewährt die Möglichkeit, kleine farbige und junge Einrichtungen zusammenzustellen, aber auch komplette und elegante, wie unten abgebildet.

LA FLOR:

Es una particularidad de toda la colección. Ha sido creada para ofrecer la posibilidad de personalizar el cuarto de baño expresando nuestra fantasía.

Se pueden decorar los lavabos, los complementos, los espejos y los revestimientos.

Estando en tema y como complemento, también han sido realizados accesorios, soportes de pie, apliques y plafones.

La colección además está compuesta por lavabos, repisas, muebles para el lavabo, muebles colgantes y cajones con sistemas de apertura realmente particulares.

Cabe resaltar el cajón y el mueble pénsil, dos objetos proyectados para ofrecer la posibilidad de gozar de dos funcionalidades en un solo elemento, apoyo y contenedor, satisfaciendo así todas las exigencias.

Esta colección permite crear pequeñas decoraciones coloradas y jóvenes, pero a la vez completas y elegantes, como las que se muestran a continuación.



Composizione 1







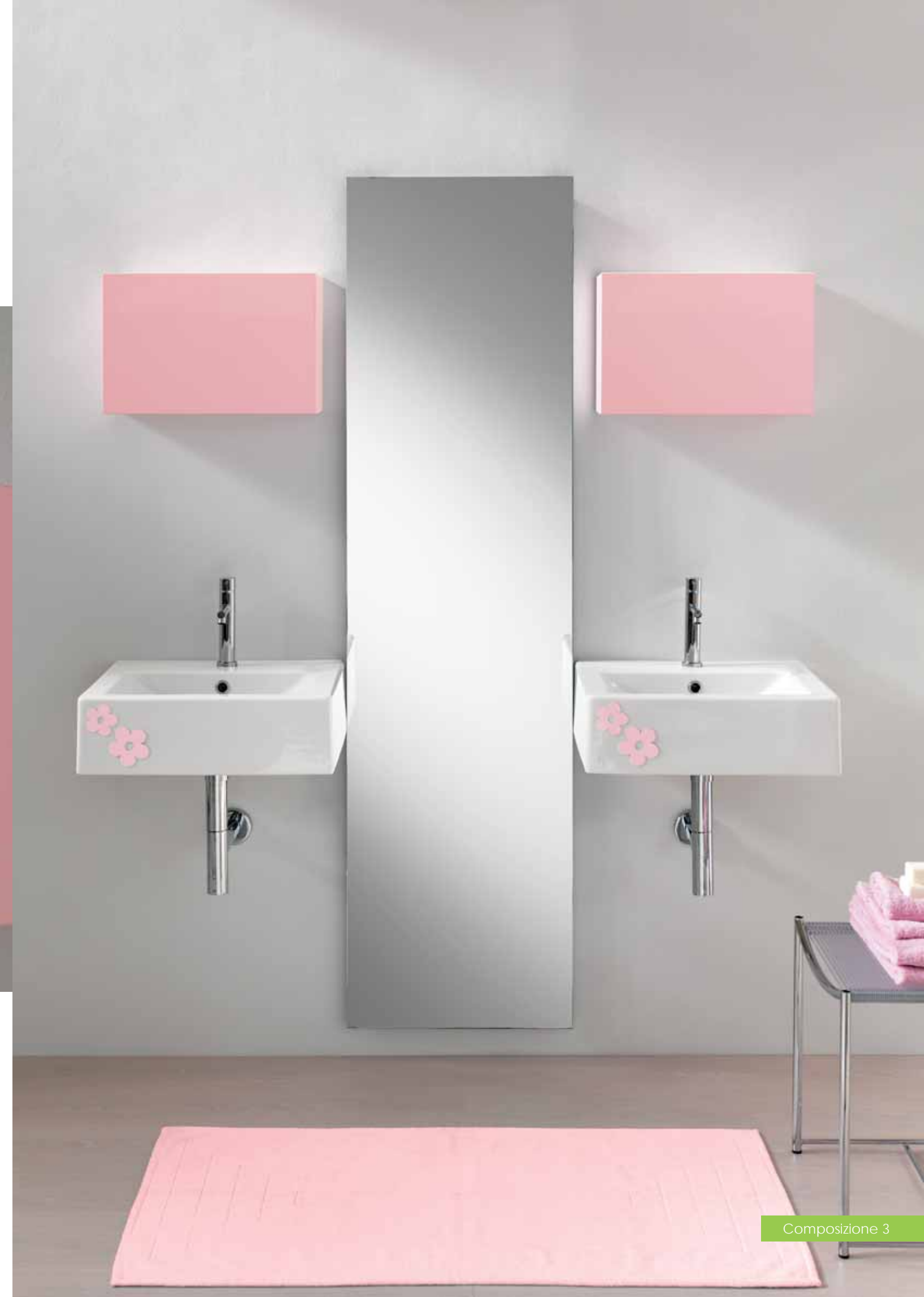

Composizione 3

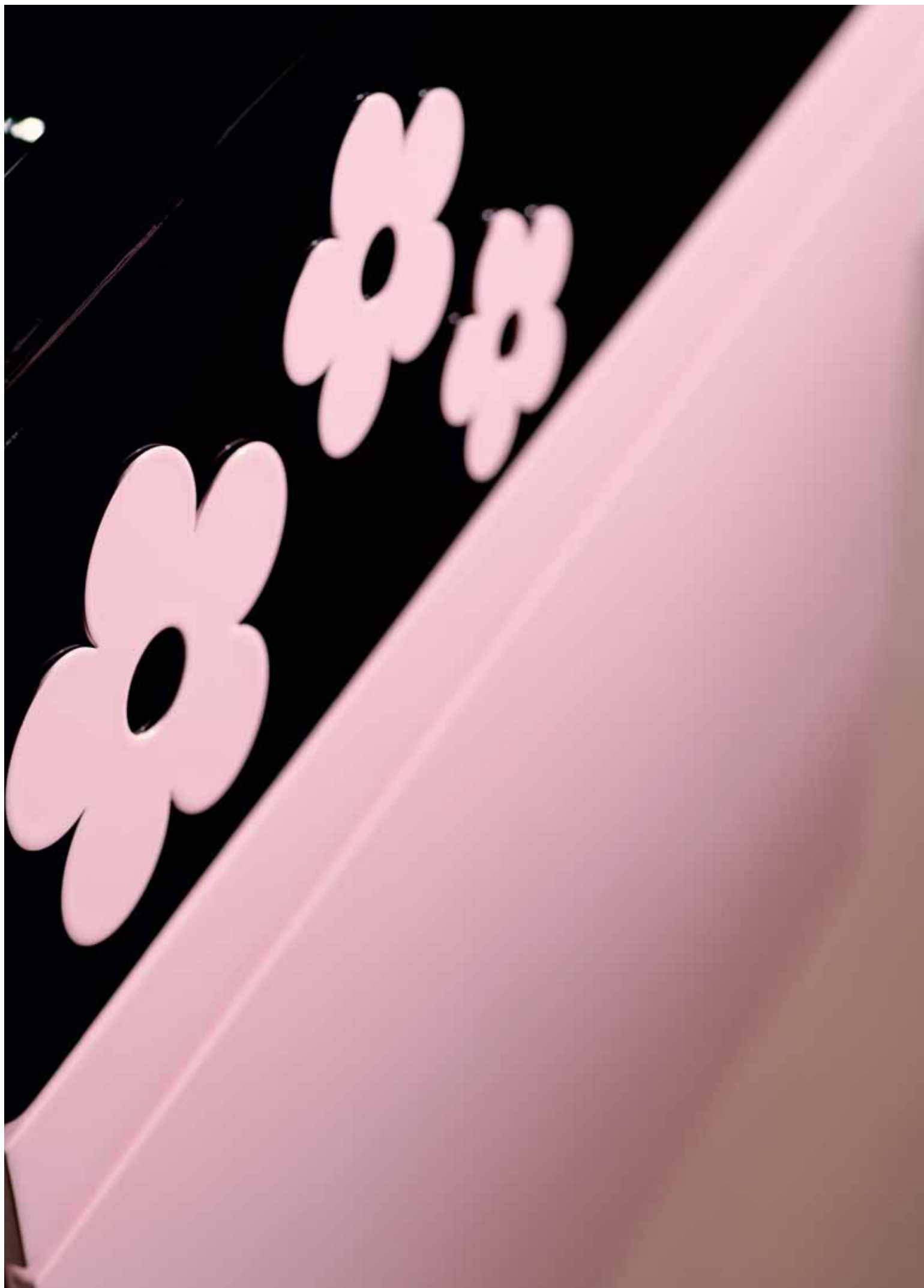



Composizione 4

























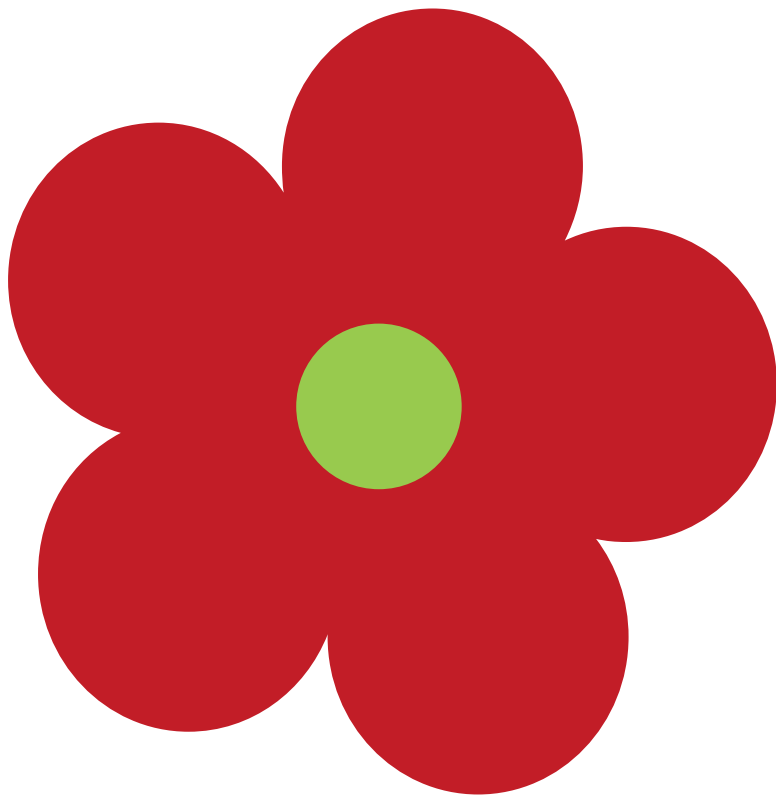























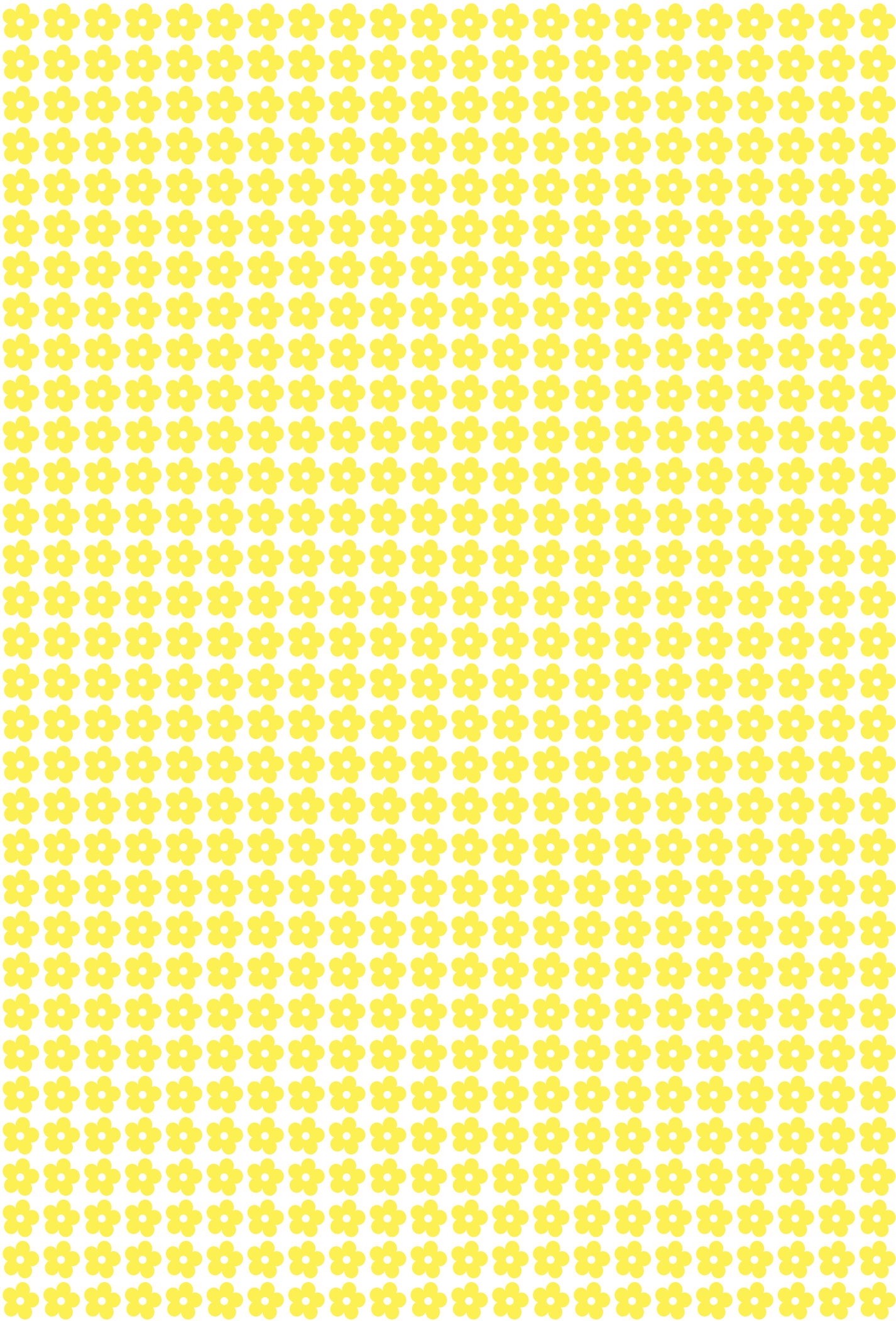















FIORE:

In acciaio inox verniciato, per garantire la massima qualità e resistenza nei colori lucidi.
VERDE ROSSO GIALLO BIANCO NERO CROMO PRUGNA ROSA.

FLOWER:

Stainless-steel item varnished ensuring maximum quality and resistance for glossy colours:
green, red, yellow, white, black, chrome, plum or pink.

FLEUR:

en acier inox vernissé pour assurer la plus grande qualité et résistance. Existe dans les versions polies: vert, rouge, jaune, blanc, noir, chromé, prune ou rose.

FLOR:

de acero inoxidable barnizada para garantizar la máxima calidad y resistencia, en los colores brillantes verde, rojo, amarillo, blanco, negro, cromo, morado o rosado.

BLUMENMOTIV:

lackiertem Edelstahl, um bestmögliche Qualität und Resistenz zu gewähren, in den Glanzfarben: grün, rot, gelb, weiß, schwarz, pflaume, rosa oder Chrom.

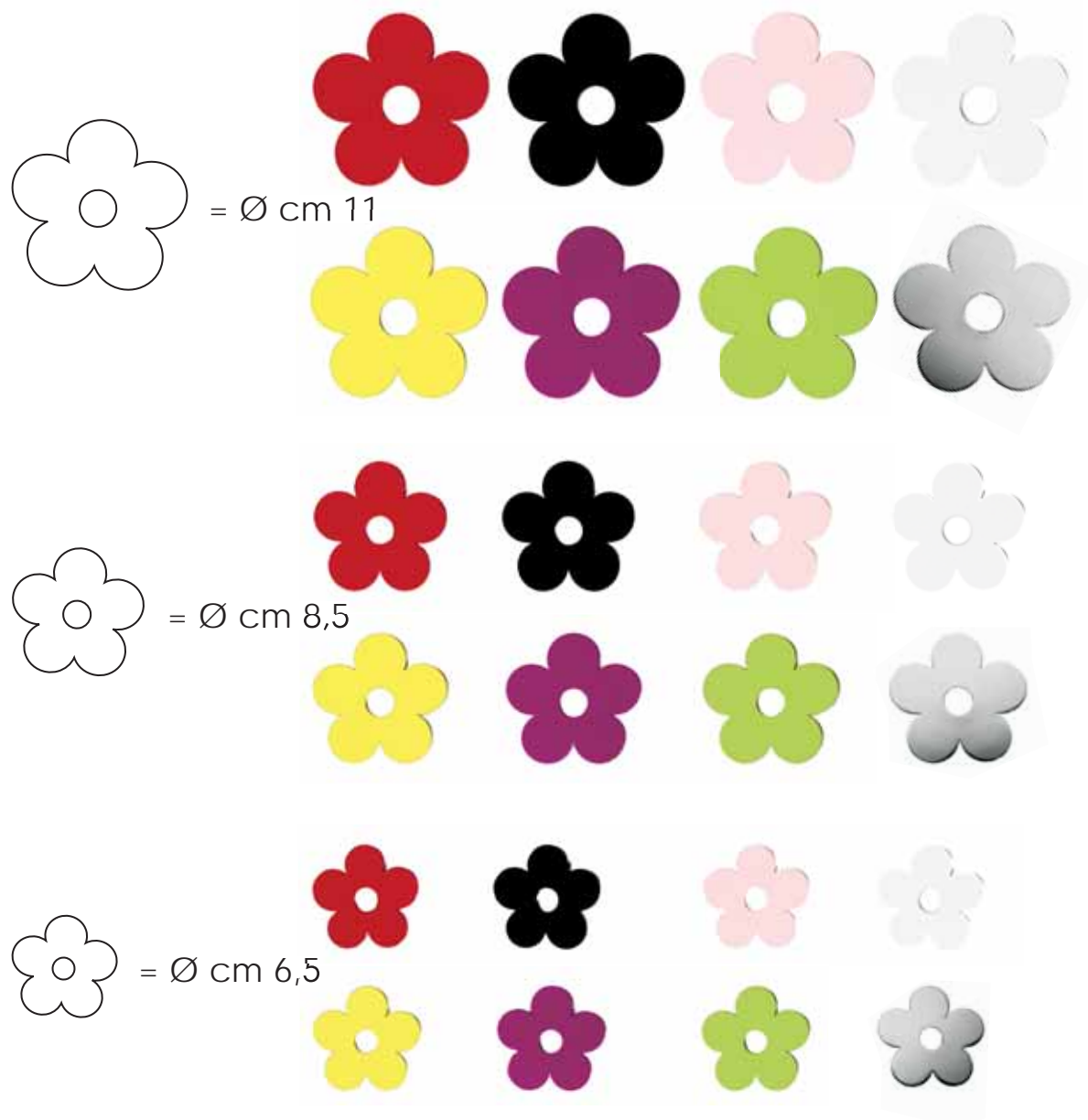

In dotazione l'apposito collante sull'acquisto dei fiori singoli.

Single flowers are complete with a special adhesive.

Les fleurs achetées individuellement sont équipées de leur colle.

Con la compra de las flores por separado se incluye la cola específica.

Beim Erwerb der einzelnen Blumenornamente wird der entsprechende Kleber mitgeliefert.



LAVABO:

In ceramica lucida. Nei colori BIANCO, GIALLO, VERDE, NERO.
Misure: L. cm 51 P. cm 46 h. cm 15

WASHBASIN:

White, yellow, green, or black glossy ceramic.

LAVABO:

En céramique luisante, dans les versions: blanc, jaune, vert ou noir.

LAVABO:

De cerámica brillante de color blanco, amarillo, verde o negro.

WASCHBECKEN:

Aus Hochglanzkeramik in den Farben weiß, gelb, grün oder schwarz.

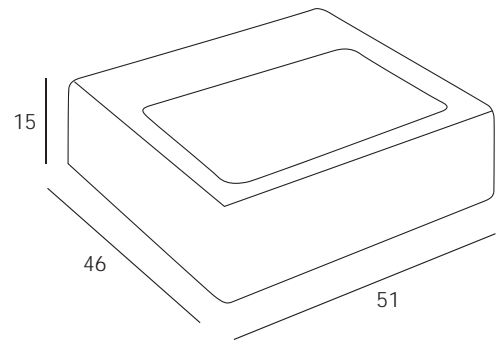



CASSETTO:

In MDF nobilitato laccato lucido con apertura scorrevole superiore nei colori, PRUGNA, ROSA, ROSSO, BIANCO, VERDE.

Misure: L. cm 45 P. cm 45,5 h. cm 15

Due funzioni in un solo elemento!

DRAWER:

lacquered glossy MDF with upper sliding opening.

Colours: plum, pink, red, white, or green.

Two functions in one single item!

TIROIR:

en MDF laqué poli avec ouverture supérieure coulissante.

Existe dans les versions: prune, rose, rouge, blanc ou vert.

Deux fonctions assurées par un seul élément!

CAJÓN:

de MDF laqueado brillante con apertura superior corrediza.

En los colores: morado, rosado, rojo, blanco o verde.

¡Dos funciones en un solo elemento!

BEHÄLTER:

aus lackiertem Hochglanz-MDF mit oberer Drehöffnung.

In den Farben: pflaume, rosa, rot, weiß oder grün.

Zwei Funktionen in einem einzigen Element!

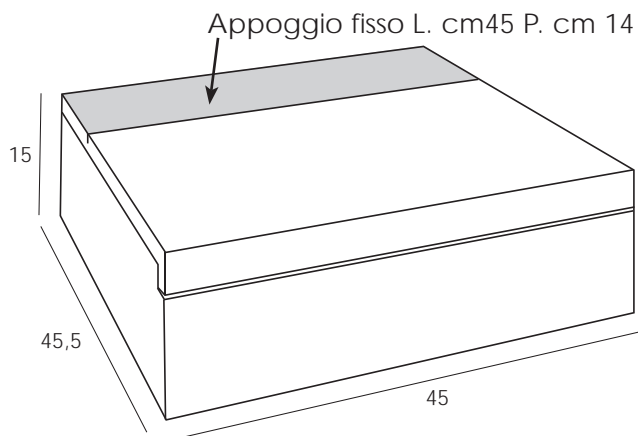



MENSOLA:

In MDF nobilitato laccata lucida nei colori:
PRUGNA, ROSA, ROSSO, BIANCO, VERDE.

Misure: L. cm 45 P. cm 17 h. cm 15

SHELF:

lacquered glossy MDF.

Colours: plum, pink, red, white, or green.

TABLETTE:

en MDF laqué poli.

Existe dans les versions: prune, rose, rouge, blanc ou vert.

REPISA:

de MDF laqueado brillante.

En los colores: morado, rosado, rojo, blanco o verde.

REGAL:

aus lackiertem Hochglanz-MDF.

In den Farben: pflaume, rosa, rot, weiß oder grün.

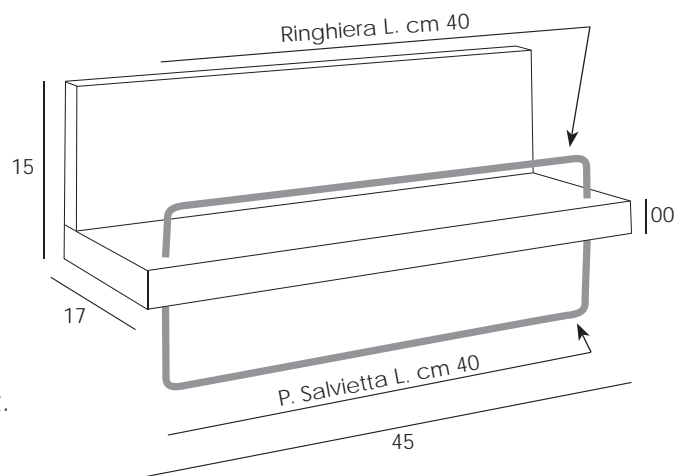



PENSILE:

In MDF nobilitato laccata lucida nei colori:
PRUGNA, ROSA, ROSSO, BIANCO, VERDE.

Misure: L. cm 45 P. cm 20 h. cm 30

Due funzioni in un solo elemento!

SHELF:

lacquered glossy MDF with drop-leaf opening.

Colours: plum, pink, red, white, or green.

Two functions in one single item!

TABLETTE:

en MDF laqué poli avec ouverture abattante.

Existe dans les versions: prune, rose, rouge, blanc ou vert.

Deux fonctions assurées par un seul élément!

REPISA:

de MDF laqueado brillante con apertura abatible.

En los colores: morado, rosado, rojo, blanco o verde.

¡Dos funciones en un solo elemento!

REGAL:

aus lackiertem Hochglanz-MDF mit Klapptür.

In den Farben: pflaume, rosa, rot, weiß oder grün.

Zwei Funktionen in einem einzigen Element!

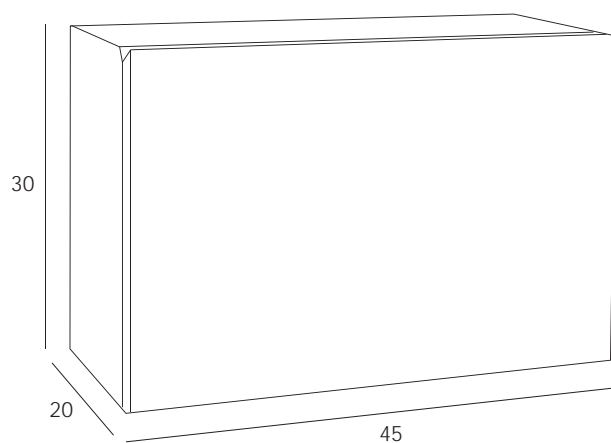



MOBILE CONTENITORE SOTTO LAVABO:

In MDF nobilitato laccato lucido nei colori: PRUGNA, ROSA, ROSSO, BIANCO, VERDE, con possibilità d'inserimento maniglia

Misure: L. cm 51 P. cm 45,5 h. cm 40

UNDER-WASHBASIN PIECE:

plum, pink, red, white or green lacquered glossy MDF with the possibility to add an handle.

MEUBLE RANGE-TOUT À PLACER SOUS LE LAVABO:

en MDF laqué poli. Existe dans les versions: prune, rose, rouge, blanc ou vert. Poignée insérable en option.

MUEBLE PARA COLOCAR DEBAJO DEL LAVABO:

de MDF laqueado brillante de color morado, rosado, rojo, blanco o verde con la posibilidad de colocarle una manilla.

UNTERSCHRANK FÜR WASCHECKEN:

aus lackiertem Hochglanz MDF in den Farben: pflaume, rosa, rot, weiß oder grün, Möglichkeit des Hinzufügens eines Türgriffs.

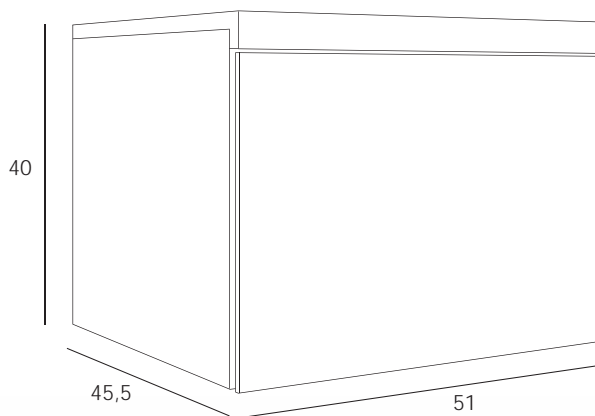



Appendiabito in ottone cromato, fiore in acciaio inox verniciato nel colore VERDE, ROSSO, GIALLO, BIANCO, NERO, CROMO, PRUGNA, ROSA.

Misure: h. cm 10 P. cm 4 Ø fiore cm 8,5

Clothes hanger chromium-plated brass, stainless-steel flower painted green, red, yellow, white, black, chrome, plum or pink.

Portemanteau en laiton chromé, fleur en acier inox peint en :vert, rouge, jaune, blanc, noir, chromé, prune ou rose.

Perchero de latón cromado, flor de acero inoxidable barnizada de color verde, rojo, amarillo, blanco, negro, cromo, morado o rosado.

Kleiderhalter in verchromtem Messing, Blumenornament aus lackiertem Edelstahl in den Farben grün, rot, gelb, weiß, schwarz, pflaume, rosa oder Chrom.



Applique flessibile a parete e dietro specchio in ottone cromato, fiore in acciaio inox verniciato nei colori: VERDE, ROSSO, GIALLO, BIANCO, NERO, CROMO, PRUGNA, ROSA.

Misure: L. 62 - Ø del fiore 16 cm

Flexible light for wall and mirror mounting chromium-plated brass, stainless-steel flower painted green, red, yellow, white, black, chrome, plum or pink.

Applique flexible murale ou à placer derrière la glace en laiton chromé, fleur en acier inox peint en :vert, rouge, jaune, blanc, noir, chromé, prune ou rose.

Aplique flexible de pared y detrás de espejo de latón cromado, flor de acero inoxidable barnizada de color verde, rojo, amarillo, blanco, negro, cromo, morado o rosado.

Bewegliche Wand- und Spiegelleuchte in verchromtem Messing, Blumenornament aus lackiertem Edelstahl in den Farben Grün, Rot, Gelb, Weiß, Schwarz, Chrom, Pflaume oder Rosa.



Plafoniera in ottone cromato, fiori in acciaio inox verniciato nei colori: VERDE, ROSSO, GIALLO, BIANCO, NERO, CROMO, PRUGNA, ROSA.

Misura: h. cm 22 - Ø base cm 25

Overhead light chromium-plated brass, stainless-steel flower painted green, red, yellow, white, black, chrome, plum or pink.

Plafonnier en laiton chromé, fleur en acier inox peint en :vert, rouge, jaune, blanc, noir, chromé, prune ou rose.

Plafón de latón cromado, flor de acero inoxidable barnizada de color verde, rojo, amarillo, blanco, negro, cromo, morado y rosado.

Deckenleuchte in verchromtem Messing, Blumenornament aus Edelstahl in den Farben grün, rot, gelb, weiß, schwarz, pflaume, rosa oder Chrom.





Piantane in ottone cromato lucido, sapone, bicchiere, dosatore, vaso scopino in acciaio inox, base a fiore, in acciaio inox verniciato nei colori: VERDE, ROSSO, GIALLO, BIANCO, NERO, CROMO, PRUGNA, ROSA.

Ø base fiore cm 25

Stands chromium-plated, glossy brass, soap, glass, soap dispenser, stainless steel brush container; stainless-steel bases in the shape of flower painted green, red, yellow, white, black, chrome, plum and pink.

Colonnes en laiton chromé poli, porte-savon, verre, doseur, porte-balayette en acier inox; supports en forme de fleur en acier inox peint en: vert, rouge, jaune, blanc, noir, chromé, prune ou rose.

Soportes de pie de latón cromado brillante, para jabón, vaso, dosificador, escobillero de acero inoxidable; bases en forma de flor de acero inoxidable barnizada de color verde, rojo, amarillo, blanco, negro, cromo, morado y rosado.

Ständer aus verchromtem Hochglanzmessing, Seife, Glas, Spender, Toilettenbürstenhalter aus Edelstahl; blumenförmige Basis aus lackiertem Edelstahl in den Farben grün, rot, gelb, weiß, schwarz, pflaume, rosa oder Chrom.





Specchi filo lucido taglio rettangolare.

Mirrors glossy profile, rectangular cut.

Glaces fil brillant, forme rectangulaire.

Espejos borde brillante, corte rectangular.

Spiegel polierte Kante, rechteckige Form

40X95X3



50X70X3



50X190X3



40X70X3



45X120X3



Ø 45X80X3 taglio mezzo cerchio

Ø 45X80X3 glossy profile, half-round cut

Ø 45X80X3 fil brillant, en forme de demi-cercle

Ø 45X80X3 borde brillante, corte en semicírculo

Ø 45X80X3 polierte Kante, Halbkreisform



INDICE COLORI FIORI



VERDE



PRUGNA



GIALLO



ROSSO



BIANCO



ROSA

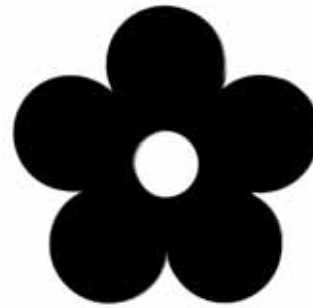

NERO



CROMO

INDICE COLORI LAVABI

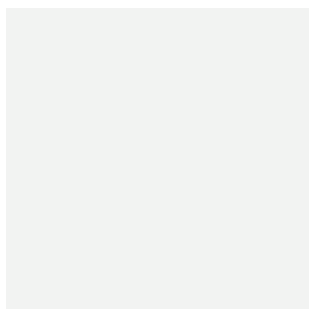

BIANCO



VERDE



GIALLO

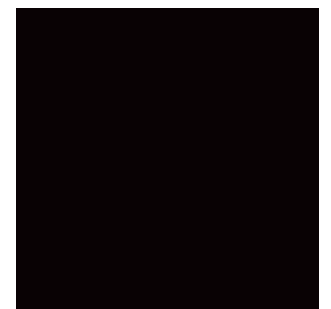

NERO

INDICE COLORI MOBILI



VERDE



PRUGNA



ROSSO

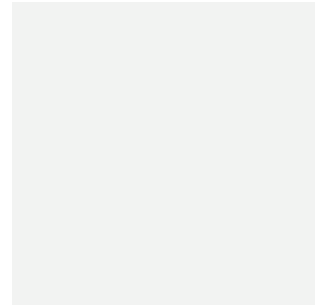

BIANCO

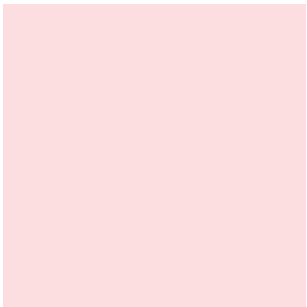

ROSA



La ditta OML, con sede a Gualtieri Reggio Emilia, è certificata UNI EN ISO 9001 - 2000, rilasciato dalla DNV (ente certificativo di livello internazionale). Questo garantisce la continua e costante affidabilità, della organizzazione OML, nell'affrontare giornalmente tutte le problematiche, dei processi operativi e produttivi, nell'acquisizione degli ordini, nelle consegne puntuali come richiesto dal cliente. L'organizzazione OML, consente severi controlli dando: un'elevata qualità dei prodotti, assoluta affidabilità nei servizi, attiva collaborazione con il cliente, ricerca di nuove soluzioni.

The company OML, with its head office in Gualtieri, Reggio Emilia, achieved certification to UNI EN ISO 9001-2000, issued by the DNV (an international level certifying body). This guarantees continuous and constant reliability of the OML organisation, on a day-to-day basis when dealing with any kind of problem, operational and production processes, order acquisition and punctual deliveries as requested by the client. OML organisation carries out strict checks, thus resulting in high quality products, absolute service reliability, active collaboration with the customer and the search for new solutions.

La société OML, dont le siège se trouve à Gualtieri (Reggio Emilia), a obtenu la certification UNI EN ISO 9001-2000, attribuée par DNV (organisme de certification à échelle internationale). Cette certification est le gage de crédibilité qu'OML offre à sa clientèle en matière d'organisation, de capacité de résolution des problématiques, comme la mise en place des procédés de fonctionnement et de production, l'acquisition des commandes, la ponctualité des livraisons comme le veut le client. L'organisation OML est synonyme de contrôles sévères pour des produits de haute qualité, une fiabilité absolue des services, une collaboration active avec le client ainsi que la recherche de nouvelles solutions.

Die Firma OML mit Sitz in Gualtieri Reggio Emilia ist laut der von der DNV (internationale Beurkundungsbehörde) ausgestellten Urkunde UNI EN ISO 9001-2000 bescheinigt. Dieses garantiert, dass die Organisation OML bei der Durchführung der operativen und produktiven Verfahren, bei der Einholung von Aufträgen und der vom Kunden geforderten pünktlichen Lieferung der Waren den täglich auftretenden Problemen entgegentritt.

Die Organisation OML nimmt strenge Kontrollen vor und bietet: qualitativ hochwertige Produkte, absolute Zuverlässigkeit in den Dienstleistungen, aktive Zusammenarbeit mit dem Kunden, Suche nach neuen Lösungen.

La empresa OML, con sede en Gualtieri (Reggio Emilia), ha obtenido la certificación UNI EN ISO 9001-2000, extendida por DNV (ente certificador de nivel internacional).

Esto garantiza la continua y constante fiabilidad de la organización para afrontar cotidianamente toda la problemática relacionada con los procesos operativos y productivos, la adquisición de pedidos y la puntualidad de las entregas, para responder plenamente a las exigencias del Cliente.

La organización OML permite la realización de severos controles, ofreciendo así una elevada calidad de los productos, absoluta fiabilidad de los servicios, activa colaboración con el Cliente y la continua búsqueda de nuevas soluciones.